

ecoline-b CONFORMS TO ALL "EN-88" REQUIREMENTS.

OIL SPECIFIC GRAVITY: 0.85  
 (NON-EMULSIFIED / FREE OIL): 850 kg/m<sup>3</sup>  
 (=53 lbs/cf)  
 OPERATING TEMPERATURE: 4-20°C (=40-70°F)  
 INFLUENT OIL CONCENTRATION: 5mg/l (=500ppm)  
 EFFLUENT OIL CONCENTRATION: 5mg/l (=5ppm)  
 FLOW RATE: 70 l/s (=1110gpm)

**PROTECTIVE INTERIOR LINING (OPTIONAL)**

1. STRUCTURE WALLS AND FLOOR TO BE CAST WITH GSE HDPE.
2. "STUDLINE" TO THE FIRST HORIZONTAL JOINT ABOVE PIPE CROWNS.
3. WELDING TO BE COMPLETED BY CERTIFIED EXTRUSION FIELD WELDERS.
4. ALL WELDS TO BE SPARK TESTED

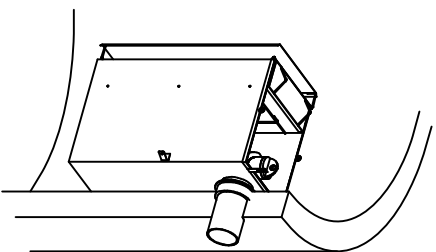

# ecoline-b 1110 gpm

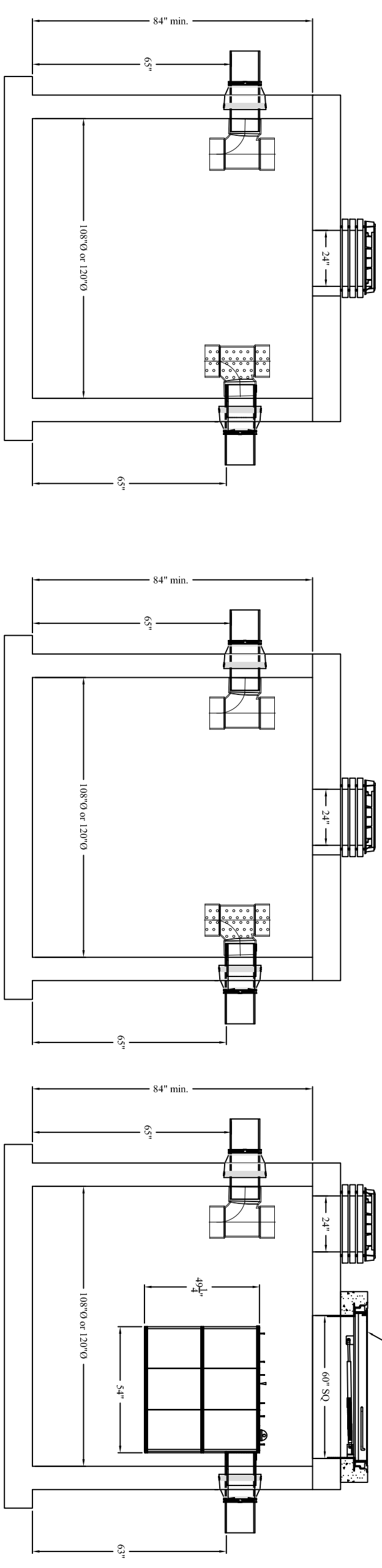
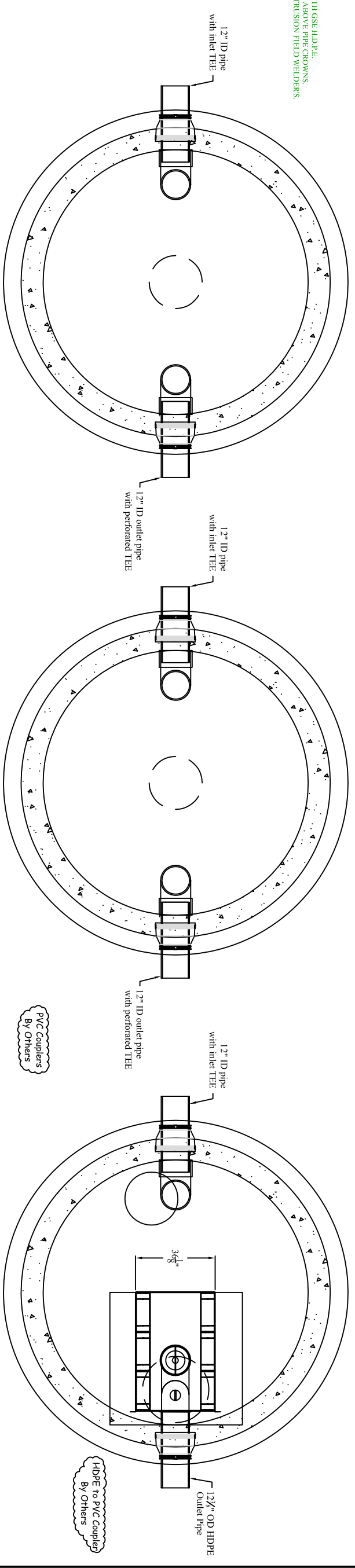

**Grit Chamber (Optional)**  
 1 - 108" Ø required (min.)  
 or 1 - 120"Ø (max.) in series  
 with same vertical dims. as  
 ecoline-b 1110gpm

**ecoline-b 1110gpm**  
 1 of 2 - 108" Ø required (min.)  
 or 1 of 2 - 120"Ø (max.) in series  
 with same vertical dims. as  
 ecoline-b 1110gpm

**ecoline-b 1110gpm**  
 2 of 2 - 108" Ø required (min.)  
 or 2 of 2 - 120"Ø (max.) in series  
 with same vertical dims.

- GENERAL NOTES:**
- MANHOLE DESIGN SPECIFICATIONS CONFORM TO LATEST ASTM C976 SPEC. FOR "PRECAST" REINFORCED CONCRETE MANHOLE SECTIONS.
  - DESIGN LOADING: HS20-44

- PROJECT NOTES:**
1. CONTRACTOR RESPONSIBLE FOR WATER/TIGHT SEALING OF ADJUSTMENT RINGS TO VAULT AND FRAME COVER.
  2. ALL PIPE TO VAULT SEALS TO BE A LOCK OR EQUAL.
  3. ANY AND ALL PIPE COUPLERS BY CONTRACTOR.
  4. HEAVIEST PIECE \_\_\_\_\_ LBS.

Proprietary Information: Patent Pending Design, All Rights Reserved - Royal Environmental Systems, Inc.  
 Royal Environmental Systems not responsible for any field testing or mitigation procedures (if required).

**ROYAL ENVIRONMENTAL SYSTEMS, Inc.**  
 A Division of Royal Enterprises America  
 (651) 462-2130  
 www.royalenterprises.net

Project:	<Project>	Location:	<Enter Location>
Owner:	<Owner>	Scale:	NTS
Engineer:	<Engineer>	Designed By:	JGS
Contractor:	<Contractor>	Date:	3-30-09
Manufacturer:	Royal Concrete Pipe	Drawing #:	ecoline-b 1110gpm
Product Designation:	ecoline-b - High-efficiency Oil Water Separator		

Drawn By: 3-30-09 JGS  
 Rev. Date: